

NOTES:
 RANGE SWITCH SHOWN IN PHONO POSITION
 "F" INDICATES SWITCH ELEMENTS ON FRONT SIDE OF WAFER.
 "R" INDICATES SWITCH ELEMENTS ON REAR SIDE OF WAFER.

IDENTIFICATION TABLE

Model	Chassis	Cabinet	Speaker	Phono Equip.
863PW	02100	02093	48997	{ 198992 25 Cycles
863PM	02100	02189	48997	{ 148993 60 Cycles
863H	02100	02091	48995	None

SPECIFICATIONS:

Power Input Rating	65 Watts
Input Power Frequency	25-60 Cycle
Intermediate Frequency	455 K.C.
Speaker Voice Coil Impedance	6-8 Ohms at 400 Cycles
Speaker	12" P.M.
Power Output	Maximum 8 Watts; 10% Distortion 4 Watts
Voltage Rating	105-125 Volts
Type of Circuit	Superheterodyne
Tuning Range	{ "A" Band 535 to 1620 K.C. "B" Band 4.5 to 9.75 Mcs. "C" Band 11.7 to 15.50 Mcs.

1948-49

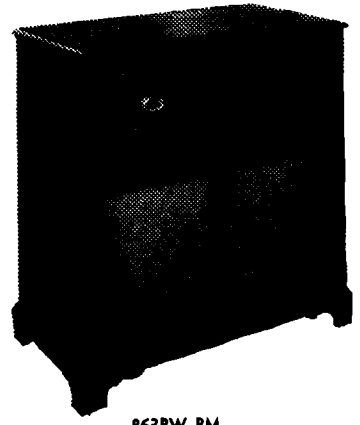

863PW-PM

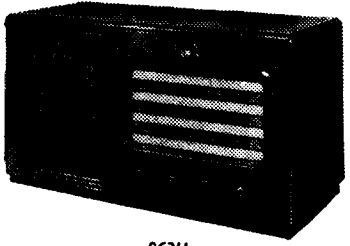

863H

IF=455 KC.

ALIGNMENT DATA
 ETC ON SHEET
 93

AC MODEL

863

TUBE LAYOUT AND ALIGNMENT TRIMMER LOCATIONS

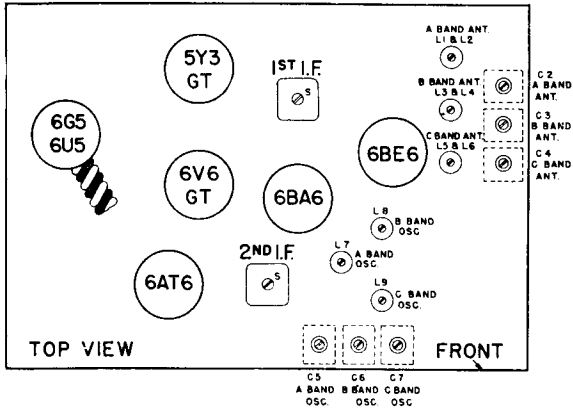

VOLTAGE CHART

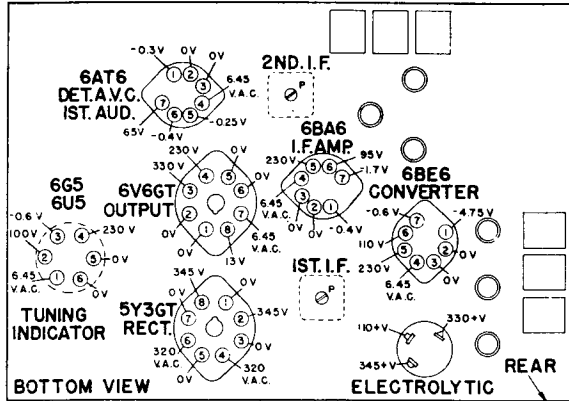

DIALCORD ARRANGEMENT

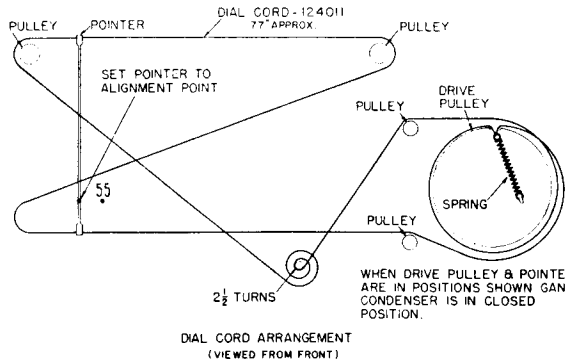

IF = 455 KC.
1948-49

AC MODEL

ALIGNMENT PROCEDURE 863

Band and Pointer Setting	Generator Setting	Input and Dummy	Output	Trimmer adjustment and notes.
I.F. ALIGNMENT				
Broadcast Low End of Dial	455 kc.	.1 mfd capacitor pin No. 1 of 6BA6 tube	Output meter across voice coil	Adjust iron cores of 2nd I.F. L12 and L13 for maximum output.
"	"	.1 mfd. capacitor pin No. 7 of 6BE6 tube	"	1. Adjust iron cores of 1st I.F. L10 and L11 for maximum output. 2. Repeat bottom core L13 of first I.F. transformer to attain maximum overall sensitivity and correct tracking. Do not adjust any other I.F. cores after this adjustment.
R.F. ALIGNMENT "A" BAND				
A Band 1500 kc.	1500 kc. 30% modulated.	Standard IRE dummy antenna or 200 mmf. capacitor in series to Ant. and Grd. terminal loop or loop substitute must be connected	Output meter across voice coil	1. Adjust B.C. oscillator trimmer capacitor C5 for maximum output and correct calibration. 2. Adjust antenna trimmer C2 for maximum output, rocking gang for correct peak. 3. Adjust B.C. oscillator iron core L7 for maximum output and correct calibration. 4. Adjust antenna coil iron core L2 for maximum output, rocking gang for correct peak. 5. Repeat 1, 2, 3, 4 until no further improvement is noted.
A Band 600 kc.	600 kc. 30% modulated	"	"	
R.F. ALIGNMENT "B" BAND				
B Band 9.5 mcs.	9.5 mcs.	400 ohm resistor (carbon) in series to ant. and grd. terminal	Output meter across voice coil	1. Adjust oscillator trimmer capacitor C6 for maximum output and correct calibration. 2. Adjust antenna trimmer capacitor C3 for maximum output, rocking gang for correct peak. 3. Adjust B band oscillator iron core L8 for maximum output and correct calibration. 4. Adjust antenna coil iron core L4 for maximum output, rocking gang for correct peak. 5. Repeat 1, 2, 3 and 4 until no further improvement is noted.
B Band 4.8 mcs.	4.8 mcs.	"	"	
R.F. ALIGNMENT "C" BAND				
C Band 15 mcs.	15 mcs.	400 ohm carbon resistor in series to antenna and ground terminals.	Output meter across voice coil	1. Adjust oscillator trimmer capacitor C7 for maximum output and correct calibration. 2. Adjust antenna trimmer C4 for maximum output, rocking gang for correct peak. 3. Adjust "C" band oscillator iron core L9 for maximum output and correct calibration. 4. Adjust antenna coil iron core L6 for maximum output, rocking gang for correct peak. 5. Repeat 1, 2, 3 and 4 until no further improvement is noted.
C Band 12 mcs.	12 mcs.	"	"	

863

CIRCUIT DATA ON SHEET 92